

FGS-50S, FGS-100L & FGS-100H Manual Test Stands

Operation Manual



Warning

Take precaution to not drop the force gauge. Damage to the sensor may occur.

Do not modify, disassemble or attempt to repair the unit. Send to the factory for proper repair.

If upon delivery damage to the unit is detected, do not operate the unit. Notify the shipping carrier immediately to obtain damage claim instructions.

Only measure forces that are in line with the measuring shaft. Do not attempt to take any measurements (tension or compression) at any angle. Failure to keep measurements in line will damage the instrument.

Ensure operation is performed on a level surface.

If applying large loads, secure test stand to a stable wall or table. For details on the force gauge, refer to the force gauge operation manual for each model.



FGS-50S



FGS-100H



FGS-100L

Set-Up Summary for Lever or Wheel Test Stand

1. Remove the bracket from the test stand using the 5mm Allen wrench included. See Force Gauge Mounting Procedure.
2. Use the mounting holes marked "A" shown on the Mounting Bracket diagram for mounting an FG force gauge with the (4) M4x8 Philips head screws included. See Force Gauge Mounting Procedure.
3. Adjust the clearance span by removing the hex bolt from the hole in the back of the stand. Loosen but do not remove the hex bolts from the (3) slots. Adjust the span by sliding the drive unit to the hole position desired and insert the hex bolt and tighten. Tighten the (3) hex bolts in the slots as well. See Span Height Adjustment Procedure.
4. Re-install the bracket with the force gauge to the test stand. See Force Gauge Mounting Procedure.
5. Carefully check travel of the stand. If necessary, adjusting the limit of the full travel of the gauge may be necessary. See Stopper Adjustment Procedure
6. Testing may now begin with the force gauge and test stand. See Measuring Procedure.

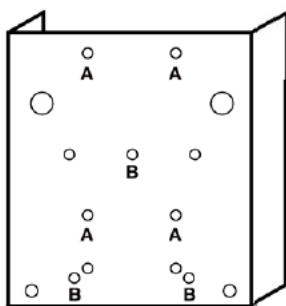

Mounting Bracket

SPECIFICATIONS

Capacity: FGS-50S: 22 kg (50 lbs.); FGS-100H/L: 200 lb (100 kg)
Travel: 1.97 in (50 mm) max.; FGS-100H: 0.12" (3 mm) / wheel turn approx. 5.9" (150 mm) max.

Clearance: FGS-50S: 1.6, 2.75, 3.94 in. (40, 70, 100 mm);
 FGS-100L: 3.31" – 11.57" (84 – 294 mm) 8 steps, 1.18"/step (30 mm/step);
 FGS-100H: 2" – 7.95" (52 – 202 mm) 6 steps, 1.18"/step (30 mm/step)

Weight: FGS-50S: 22 lbs (10 kg); FGS-100L/H: 33 lb (15 kg)

Included Accessories: Mounting bracket (1 pc.), Cable holder (1pc.), 5 mm Allen wrench (1pc.), Philips head screw M4x8 (4pcs.)

Span Height Adjustment Procedure

Step height adjustment is enabled by moving the slide assembly. Available steps vary by model. Step adjustment distance is 1.18" (30 mm).

- ① Lay the stand body with the side facing up. (Remove the cable grip beforehand.)
- ② Loosen the height adjusting bolts in three slots out of four. (Do not remove the bolts.)
- ③ While raising the slide assembly, remove the bolt from the small hole, and hold the slide assembly at an appropriate position. Then, tighten the remaining three bolts. In this step, be careful not to get your hand or finger caught between the slide assembly and the stand body.

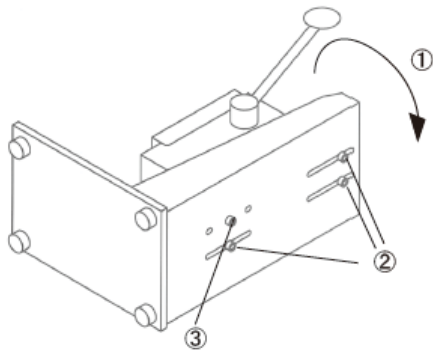

Force Gauge Mounting Procedure

1. Remove the mounting bolts by using the hexagon wrench (accessory), and remove the force gauge mounting plate.
2. Mount the force gauge to the force gauge mounting plate as shown below.
3. Mount the force gauge to the stand body by using the removed bolts.

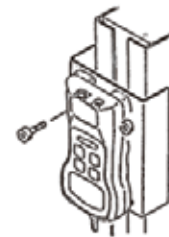
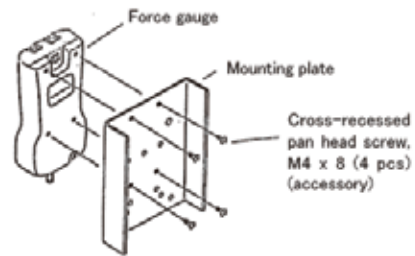
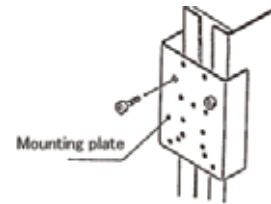

Stopper Adjustment Procedure

To set the force gauge's lower end position during measurement, adjust the stopper position according to the procedure below.

Loosen the lock nut at the bottom of the slide assembly.

1. As the adjusting bolt is screwed into the slide assembly, the stopper position is raised.
2. After positioning the stopper, tighten the lock nut to complete the stopper adjustment procedure.

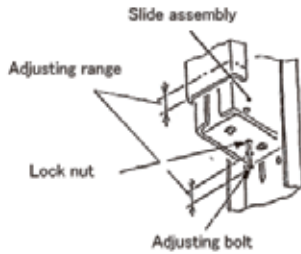

Measuring Procedure

Install the stand body on a level solid table. During measurement, operate the lever/wheel at a constant speed as smoothly as possible. If the lever/wheel operation speed is rapidly changed (to a high or low speed), accurate measurement cannot be performed. During measurement and height adjustment, use thorough caution not to apply impact to the force gauge measuring axis. If applying large loads, secure test stand to a stable wall or table. For details on the force gauge, refer to the force gauge operation manual for each model.

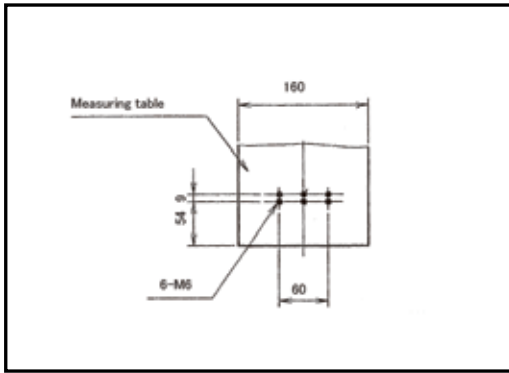

Screw Hole Positions on Measuring Table

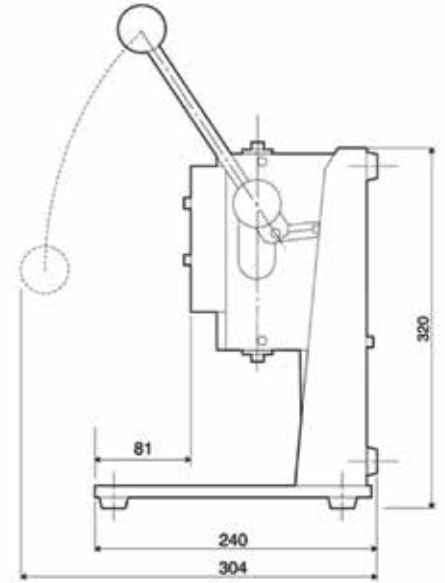
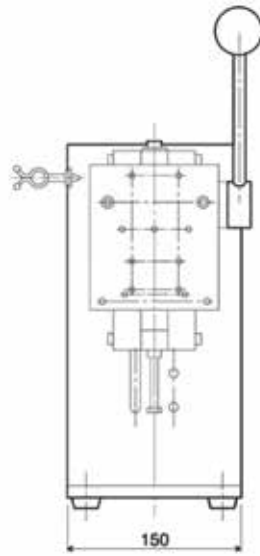

**FGS-50S
Dimensions in mm**

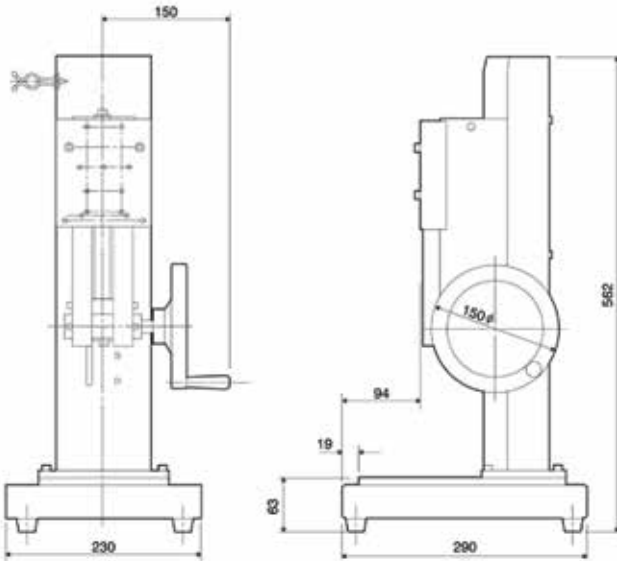

**FGS-100H
Dimensions in mm**

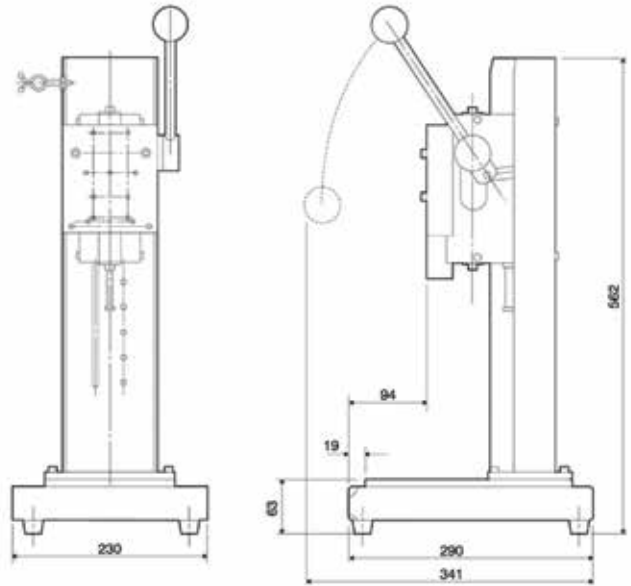

**FGS-100L
Dimensions in mm**